

# Maintainer

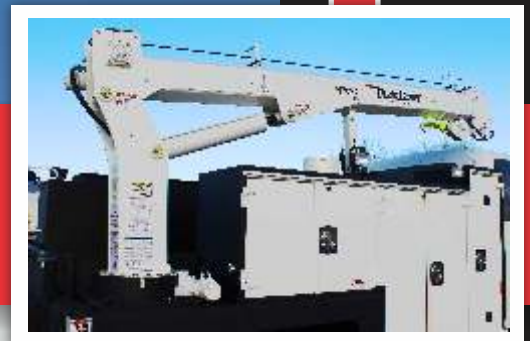

## H7024 CRANE



**CAUTION**  
UNLAWFUL TO OPERATE  
THIS EQUIPMENT  
WITHIN 10 FEET OF  
HIGH VOLTAGE LINES OF

# specifications

## short tower

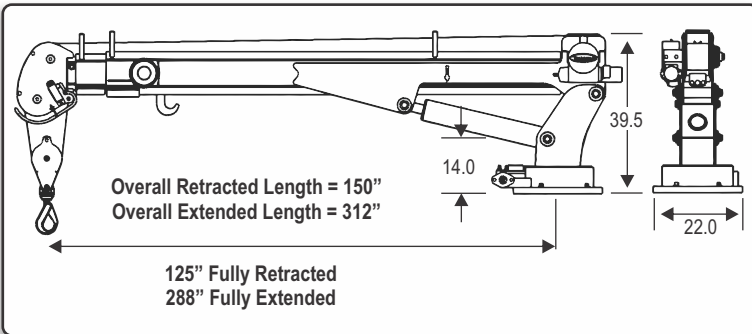

## tall tower

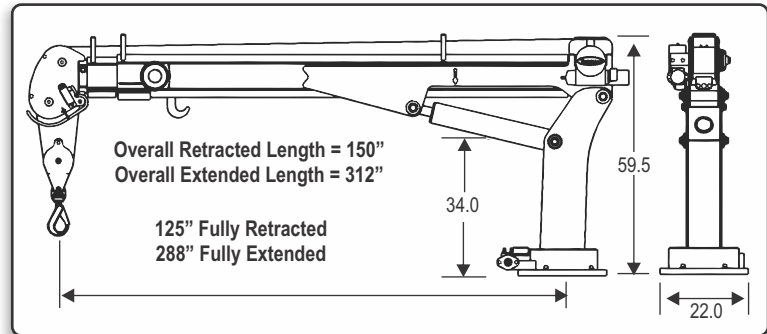

## features:

- "Boom Mounted" Worm Gear Winch - 30 fpm
- Dual Part Line (Single Part Capable)
- Weight—1,700 lb.
- Total Operational Range 91° (-13 to +78)
- Double Sheave Design
- Anti-Two Block Relocation (Inboard)
- 120 ft. of 3/8 in dia. Steel Cable
- 615° Rotation
- 24 ft. Hydraulic Reach
- Hexagonal Boom
- Tall and Short Tower Configurations
- Closed-center/Load-sensing Hydraulic System
- OSHA 1910.180 / ANSI B30.5 Compliant
- User-friendly Load Block storage
- Wireless Remote Control - standard
- Advanced Crane Control - standard



## options:

- Open-center Hydraulic System
- Planetary Winch - 60 fpm
- LED Flood Lights on Boom Tip

## ratings:

### H7024 CRANE CAPACITY CHART

45,100 FT\*LB  
CRANE RATING

MAX SINGLE LINE CAPACITY IS 4300 LBS. (1950 KG)  
FOR GREATER LOADS USE 2 PART LINE  
OUTRIGGERS MUST BE EXTENDED AND DOWN

DEDUCT FROM CAPACITIES  
THE WEIGHTS OF LOAD  
HANDLING DEVICES

HYDRAULIC  
EXTENSION  
TO 24'

CAPACITIES ARE IN LBS. (\*KGS.)

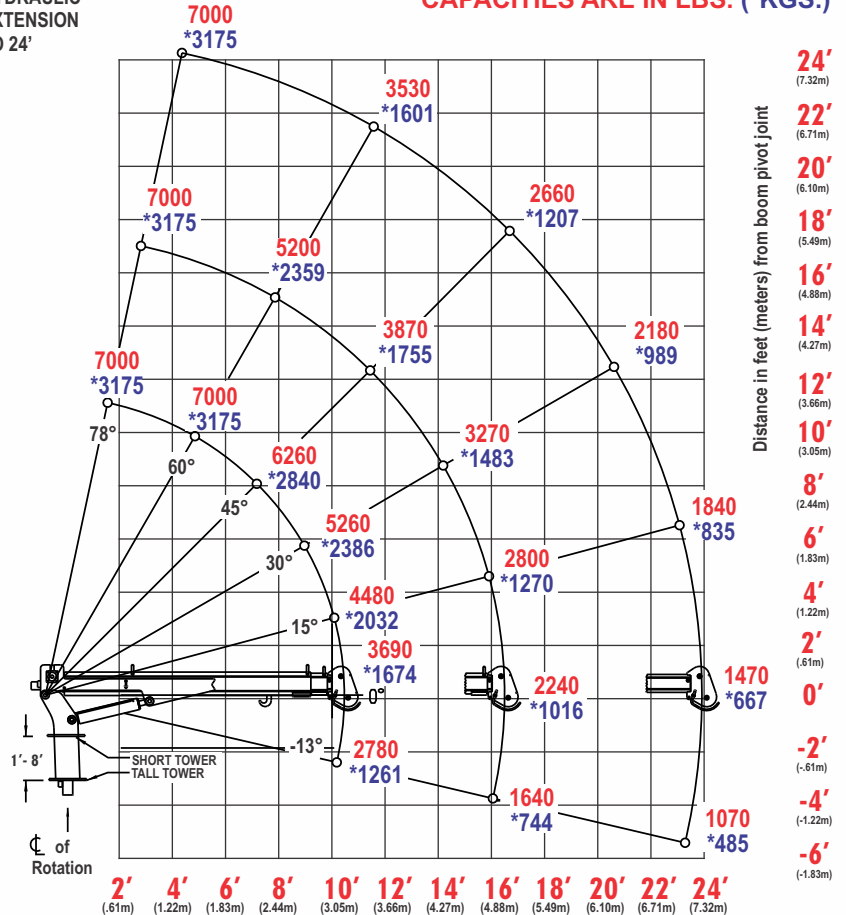

www.

**Maintainer.com**

**MAINTAINER CORPORATION OF IOWA, INC.**

1701 2nd Avenue | Sheldon, Iowa 51201 | Ph: 800-831-8588