

LUBE SKID

NEW!

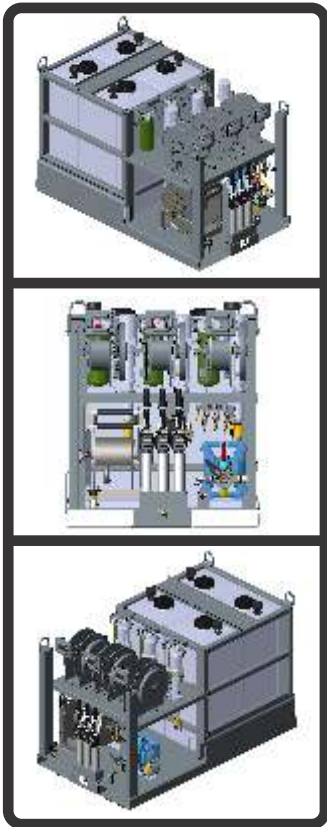

SKID DIMENSIONS: 75" L x 42" W x 49" H
SKID WEIGHT EMPTY: 1,312 lbs

Maintainer

800-831-8588 | www.maintainer.com

features:



- (3) 55 gallon poly oil tanks
- (1) 55 gallon waste oil tank
- 5:1 air pumps for new oil products
- 1/2" x 50' spring rewind oil hose reels
- 1" air diaphragm waste oil pump
- 1" x 30' spring rewind waste oil reel
- Filter screen for waste oil hose
- (3) Metered nozzles for new oil products
- (3) In-line heavy duty filters on new oil products
- Aluminum air manifold for pump operation
- (4) Heavy-duty tie-down/lifting rings
- Forklift pockets for ease of loading and unloading - located at both ends
- Hose reel mounting shelf at rear of skid
- Primed and painted standard color white

SCAN & VISIT
OUR WEBSITE

